

**Installation, Operation, and Maintenance Instructions  
Forged Stainless Steel Gate Valves  
and Forged Steel Gate Valves  
Sharpe Model Series 34836 and 34834**

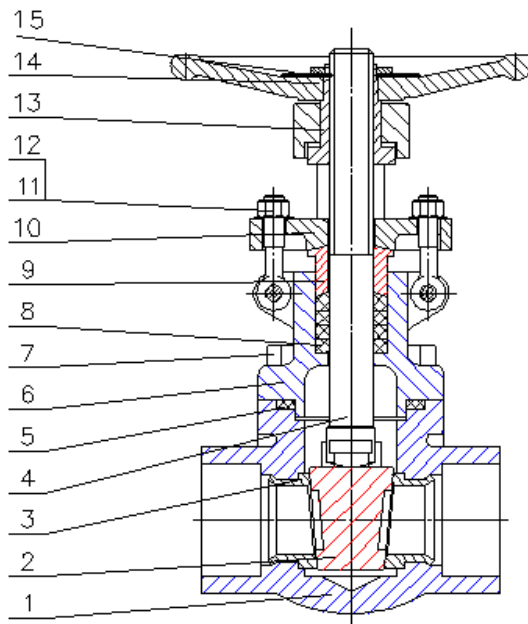

15	Name Plate	Aluminum
14	Hand Wheel	ASTM A197
13	Stem Nut	ASTM A276 410
12	Gland Nut	ASTM A194 8
11	Gland Eyebolt	ASTM A193 B8
10	Gland Flange	ASTM A182 F304
9	Gland	ASTM A276 316L
8	Stem Packing	Reinforced Graphite
7	Bonnet Bolt	ASTM A193 B8
6	Bonnet	ASTM A182 F316L
5	Gasket	Graphite+316
4	Stem	ASTM A276 316L
3	Seat Ring	ASTM A276 316L+STEL
2	Wedge	ASTM A276 316L
1	Body	ASTM A182 F316L
NO	PART NAME	MATERIAL

1. **Scope:** This instruction is applied to nominal diameter 1" – 2" CLASS 800 threaded and socket weld end, gate valves.
2. **SAFETY INSTRUCTIONS:**
  - 2.1 Read this Installation, Operation and Maintenance Manual before using the valve. Sharpe Valves cannot anticipate all the situations a user may encounter while installing and using the Sharpe Valve. The user must know and follow all applicable industry specifications on the safe installation and use of these valves. Only qualified personnel or technicians who are trained for maintenance work and have read the instructions are to assemble and disassemble the valve. Misapplication of the product may result in injuries or property damage.
3. **Applications:**
  - 3.1 Valves are to be installed in a pipeline to prevent fluid flow from either direction. It can be installed in vertical or horizontal position.
  - 3.2 Stainless steel valves are suited to corrosive service. Please consult Sharpe Valve for special applications.
  - 3.3. Material Pressure-Temperature Rating – Please see table below:

**ASTM A182 Gr. F316**

Temperature	ASTM A182 Gr. F316L (PSIG)
-20 to 100	1600
200	1363
300	1216
400	1120
500	1048
600	991
650	973
700	960
750	941
800	920

**ASTM A105**

Temperature	ASTM A105 (PSIG)
-20 to 100	1973
200	1806
300	1746
400	1689
500	1608
600	1515
650	1466
700	1413
750	1351
800	1098

**4. Operation:** Fluids flow through gate valves in straight line path. There is little resistance to flow and the resulting pressure drops are small. A gate like disk (wedge) is actuated by the screw and hand wheel. The gate valve is closed by turning the hand wheel clockwise until it hits dead end and sitting tightly between the seats (fully closed). The stem rises when the valve is being opened by turning the hand wheel counter-clockwise until it stops (fully open).

**5. Storage and Protection:**

5.1 Valves shall be stored in a dry warehouse, with end covers installed.

5.2 For long term storage, valves shall be checked periodically, and cleaned to remove dirt and foreign material. Special care shall be taken for the cleanliness of seat surfaces, to prevent damage to the seat and disc or wedge.

**6. Pre- Installation Check List:**

6.1 Before installing the valve, check the valve identification tag carefully to verify that it is the correct valve for the application.

6.2 Remove the plastic cap from both ends, check inside passage and seal surface. Clean as necessary to remove all dirt and foreign material.

6.3 Check for loose nuts, bolts and stem thread damage. Turn the valve fully open and fully closed to make sure it is operating properly.

6.4 Installation technician must follow all the safety standards and codes national and local imposed for his system.

**7. Inspection Maintenance and Disassembly:**

7.1 Make sure there is no pressure in the line before performing any maintenance on the valve.

7.2 For valves welded in the line. Skip 7.3 and 7.4

7.3 Remove the valve from the line. Work in a clean, free of dust, debris, and well lighted area. For safety and comfort, do the repairs on a table with a vise.

7.4 Clamp the valve body to the vise.

7.5 Remove the cover bolts to separate the cover with top assembly from the body.

7.5 Check and replace damaged cover gaskets.

7.6 Examine the wedge and seat surfaces for damage. Excessive wear may require replacement of the damaged component. Minor damage or wear may be repaired by re-lapping or stoning the seat faces. For valves welded in the line with damaged seats, repair of the seats is very difficult or impossible. Valves may have to be replaced.

**8. Reassembly:**

8.1 Reassemble the valve in the reverse order of disassembly.