

**Installation, Operation, and Maintenance Instructions  
 Forged Stainless Steel Piston Check Valves  
 and Forged Steel Piston Check Valves  
 Sharpe Model Series 24836 and 24834**

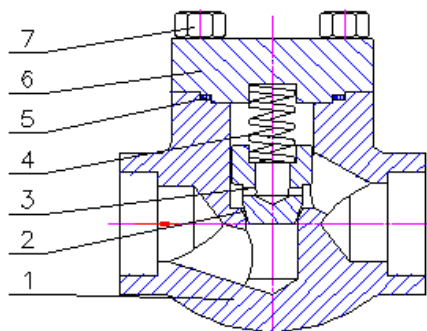

NO	PART NAME	MATERIAL
1	BODY	ASTM A182 316L
2	SEAT	ASTM A182 316
3	PISTON	ASTM A182 316
4	SPRING	ASTM A316
5	GASKET SPIRAL WOUND	GRAPHITE + 316
6	COVER	ASTM A182 316L
7	BOLT	A193/B8

1. **Scope:** This instruction is applied to nominal diameter 1" – 2" CLASS 800 threaded and socket weld end, piston check valves.

**2. SAFETY INSTRUCTIONS:**

2.1 Read this Installation, Operation and Maintenance Manual before using the valve. Sharpe Valves cannot anticipate all the situations a user may encounter while installing and using the Sharpe Valve. The user must know and follow all applicable industry specifications on the safe installation and use of these valves. Only qualified personnel or technicians who are trained for maintenance work and have read the instructions are to assemble and disassemble the valve. Misapplication of the product may result in injuries or property damage.

**3. Applications:**

- 3.1 Valves are to be installed in a pipeline to prevent fluid flow from reversing direction.
- 3.2 Stainless steel valves are suited to corrosive service. Please consult Sharpe Valve for special applications.
- 3.3. Material Pressure-Temperature Rating – Please see table below:

Temperature	ASTM A182 Gr F316L (PSIG)
-20 to 100	1600
200	1363
300	1216
400	1120
500	1048
600	991
650	973
700	960
750	941
800	920

Temperature	ASTM A105 (PSIG)
-20 to 100	1973
200	1806
300	1746
400	1689
500	1608
600	1515
650	1466
700	1413
750	1351
800	1098

**4. Operation:** The Check valve piston is automatically opened or closed by fluid flow; allowing flow in the preferred direction and preventing flow in the reverse direction.

**5. Storage, Protection, and Installation:**

- 5.1 Valves shall be stored in a dry warehouse, with end covers installed.
- 5.2 For long term storage, valves shall be checked periodically, and cleaned to remove dirt and foreign material. Special care shall be taken for the cleanliness of seat surfaces, to prevent damage to the seat and disc.
- 5.3 Before installing the valve, check the valve identification tag carefully to verify that it is the correct valve for the application.
- 5.4 Before installing the valve, check inside passage and seal surface. Clean as necessary to remove all dirt and foreign material.
- 5.5 When installing the valve, make sure that the flow arrow on the valve points in the required direction of flow.

**6. Inspection Maintenance and disassembly:**

- 6.1 Make sure there is no pressure in the line before performing any maintenance on the valve.
- 6.2 Remove the bolts to separate the cover from the body.
- 6.3 Remove the spring and the piston off the body. Check and replace broken spring.
- 6.4 Check and replace damaged gaskets.
- 6.5 Examine piston and seat surfaces for damage. Excessive wear or wire-drawing may require replacement of the damaged component. Minor damage or wear may be repaired by re-lapping or stoning the seat faces.

**7. Reassembly:**

- 7.1 Reassemble the valve in the reverse order of disassembly.