

SERIES 13 DIR-ACT® 3-PIECE BALL VALVE INSTALLATION, OPERATION, AND MAINTENANCE INSTRUCTIONS

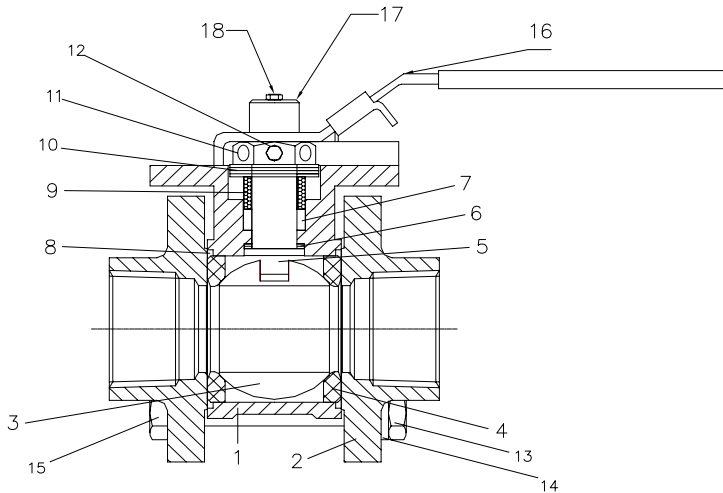

NO	(PART NAME)
1	BODY
2	PIPE ENDS
3	BALL
4	SEAT
5	STEM
6	THRUST BEARING
7	STEM PACKING
8	BODY SEAL
9	GLAND PACKING
10	BELLEVILLE WASHERS
11	PACKING NUT
12	SET SCREW
13	BOLT NUT
14	BOLT WASHER
15	BOLT
16	HANDLE
17	HANDLE RETAINER
18	CAPSCREW

INSTALLATION:

These valves may be installed in the pipeline in any orientation or position, using good piping practice. For threaded end valves, use a suitable joint compound or TFE tape on pipe threads for ease of fit-up.

WELDING END VALVES:

Socket weld and butt weld end valves must be partially disassembled to prevent heat damage during welding of the soft plastic seats and seals in the valve. Prior to disassembly, the valve may be temporarily fitted in line, and the ends tack-welded to the piping for alignment purposes.

With the valve in the open position, remove the body hex nuts and lock washers, and the body hex bolts. Carefully lift out the center section, making sure that the seats and body seals are held in position. Place the center section in a clean area where it will not be damaged, and complete the welding of the end caps to the piping.

When the welds are cool to the touch, reinstall the center section of the valve between the body end caps. Take care that the seats and seals are in place, and have not been damaged. Re-install the body bolting, and tighten following the "Assembly" instructions on the following page.

OPERATION:

These are quarter-turn (90° rotation) ball valves, and are normal fitted with a latching lever handle for manual operation. The handles also contain travel stop tabs at the open and closed positions. To open the valve, lift the latch/lock slider up, and turn the handle clockwise. To close the valve, lift the latch/lock and turn the handle counterclockwise.

For valves fitted with power actuators, operating instructions are contained in the manuals supplied with the actuator and accessories.

MAINTENANCE:

----WARNING----
**Do not attempt to perform
maintenance on valves in
pressurized lines.**

STEM SEAL ADJUSTMENT:

The stem nut can be tightened to compress the stem packing without removing any actuation devices. This adjustment should not be required frequently because of the live loading of the stem packing by Belleville springs between the stem nut and the metal Gland Packing ring.

Tightening the stem nut is easiest with the valve in the closed position. The stem must be held in position while stem nut adjustments are made. This can be done by holding the handle or putting a wrench on the stem flats, or using the actuator to position the valve.

There are holes drilled and tapped in the sides of the stem nut and a hex socket head set screw is located in one of the holes to lock the stem nut to the stem. Loosen the set screw, and insert the allen wrench or hex key into one of the stem nut holes visible in the open corner of the actuator mounting pad. Turn the nut one-quarter turn clockwise (as viewed from above). If this is not sufficient, make a second adjustment of a quarter turn.

If the stem nut turns very easily, the Belleville springs are likely not compressed. Tighten the stem nut until it feels snug, and the Belleville springs appear flat.

If these adjustments do not eliminate the stem seal leakage, then replace the stem packing.

SEAL REPLACEMENT:

Turn valve to the open position and remove handle nut, lock washer, and handle. Loosen and remove packing gland from valve body.

Loosen and remove body bolts, and remove body center section assembly, placing it on a suitable work surface. Remove seats and body seals.

Using the handle if necessary, turn ball to the closed position, and remove ball from body with a rolling motion away from the stem. Handle ball with care to avoid damaging the surface.

Push downwards on the top of the stem to slide it through the stem seals, and remove stem from inside body bore. Remove thrust washer from stem, or from body bore if retained in body. Remove stem seals using a packing hook or sharp object.

Sharpe recommends that all soft parts, including seats be replaced with new parts, which can be ordered in kit form.

REASSEMBLY:

Make sure all valve components are clean and undamaged before assembly.

Install thrust washer on stem, and slide down to shoulder. Insert stem into body and upwards through the stem bore until the shoulder is seated in the bore.

Slide stem seal over stem top, and into stem bore in body. Take care not to damage seal on stem threads. Install packing gland, and tighten finger tight.

Place stem in the "closed" position, and install the ball carefully by rolling the stem tang into the ball slot.

Install seats in the body at both ends, making sure the concave face fits against the ball, and press the body seals into the grooves in the body faces.

Turn ball to the "open" position, and replace between the end caps in line. Slide body hex bolts through end caps and body guide holes, and secure with lock washers and hex nuts. Tighten snugly.

Tighten packing gland to the torque value given in the table below, and replace the handle, lock washer, and handle nut.

Tighten the body bolting to the torque values given in the table below, using a cross or star pattern.

Table 1 – Assembly Torques

Valve Size	Gland Torque (in-lb)	Body Bolt Torque (in-lb)
1/4" – 3/8"	35	50
1/2"	35	110
3/4" – 1"	80	115
1-1/4" – 1-1/2"	115	120
2"	115	125
2-1/2"	250	350
3" – 4"	350	460



1260 Garnet Drive, Northlake, Illinois 60164-1028 Phone (877) 774-2773 Fax: (708) 562-0890 www.sharpevalves.com