

Installation, Operation, and Maintenance Manual

Series 50 / FS50 Flanged Ball Valves

Sizes 6" - 12" , Classes 150 & 300

NO.	PART NAME
1	BODY
2	CAP
3	STEM
4A	GLAND
4B	GLAND RING
5	BALL
6	SEAT
7	PACKING
8	THRUST WASHER
9	GASKET
10	STEM BEARING
11	ANTI-STATIC
12	TRAVEL STOPPER
13	SNAP RING
14	HANDLE
15	STUD
16	NUT
17	GLAND BOLT
18	PIN SEAT
19	PIN PACKING
20	SUPPORT PIN
21	SUPPORT NUT
22	SET NUT
23	TUNING SCREW

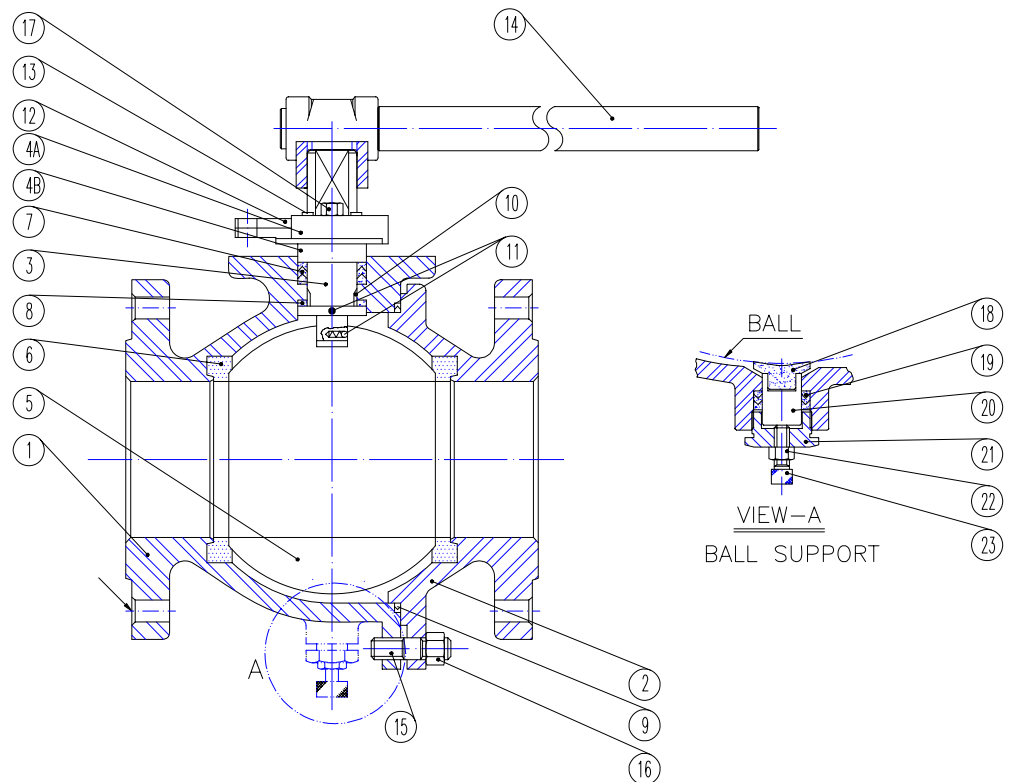

DESCRIPTION:

Split body, two piece construction full port ball valve. Design allows maintenance without the need for special tools. Ball support supplied for 10" and 12" Class 150 valves, and 6" through 12" Class 300 valves.

INSTALLATION:

1. Before installing the valves, the pipes must be flushed clean of dirt, burrs and welding residues, or you will damage the seats and ball surface.

2. These valves may be installed in any position using good pipe fitting practices. Flanges conform to ASME Standard B16.5, Class 150 or Class 300.
3. Periodically check and tighten body joint and flange bolting. (See TABLE 1 for torque requirements.)

MANUAL OPERATION:

1. The valve is opened and closed by turning the handle $\frac{1}{4}$ turn (90°). Turning the handle clockwise closes the valve (handle perpendicular to pipeline). Turning the handle counterclockwise opens the valve (handle parallel to pipeline).

AUTOMATED OPERATION:

1. Valves with Actuators should be checked for alignment of the actuator to the valve. Angular or parallel misalignment may result in high operational torque, and potential damage to the stem seals or stem.

STEM SEAL ADJUSTMENT:

1. Stem seal leakage may be corrected without disassembly. If leakage is evident in stem packing area, tighten the gland bolts $\frac{1}{4}$ turn, each. If leakage persists, repeat above. Replacement of stem seals is indicated if the leak is still apparent after $\frac{1}{2}$ turn.

DISASSEMBLY:

-CAUTION-

If the Valve has been used to control hazardous media, it must be decontaminated before disassembly.

---WARNING---

Do not attempt to repair or partially disassemble a valve while it is in line and under pressure. Isolate the line, de-pressurize, and remove valve prior to performing maintenance.

1. Remove flange bolts and nuts and lift valve from line. Care should be taken to avoid scratching or damaging flange facings.
2. Remove handle, snap ring, and travel stop plate.
3. Remove gland bolts, gland, and gland ring from stem.
4. Remove body end nuts, using proper wrench size. Lift off body end. One seat should come out with body end.

5. Remove body seal.
6. **For 10" and 12" valves only:** Ball support must be backed off to remove ball. Loosen support nut, set nut and back out tuning screw on bottom of valve to release the ball support. The weight of the ball will cause the ball support to come down.
7. To take out the ball, rotate stem so ball is in fully closed position. Carefully lift ball off stem tang and from body with a "rolling" motion. Use a strap and lift device, if necessary. Note: Extreme caution should be taken to avoid damage to the ball.
8. Take out other seat.
9. Stem must be removed from inside the body. The thrust bearing should come out with the stem. Then remove the stem packing and stem bushing.

VISUAL INSPECTION:

1. Clean and inspect all metal parts. Replace the ball and/or stem if the seating or sealing surfaces have been damaged, worn, or corroded.
2. Stem seals, seats, and body seal must be replaced whenever the valve is disassembled to avoid seal leakage and ensure proper performance.

ASSEMBLY:

Note: The valve may be assembled and operated dry where no lubricants are allowed in the system; however, a light lubrication of mating parts will aid in assembly and reduce initial operating torque. Lubricant used must be compatible with the intended line fluid.

1. Set the valve body on a clean work surface, resting on the end flange.
2. Install one seat in the body cavity with the spherical curvature facing the ball (upwards).
3. Cut new stem bushing on one side at approx. 30° - 60° angle and wrap around stem above shoulder.
4. Install thrust bearing on stem and holding stem bushing in place, slide the stem up through stem bore from inside body.
5. Install new stem seals, gland ring, and gland. Install gland bolts and tighten hand tight.
6. Install travel stop, and snap ring.

7. Turn the stem to the CLOSED position (bottom stem tang parallel to flow passage). Line up the ball slot with the stem tang and roll and lower the ball into position on the stem tang, letting the ball rest in the seat. Turn the stem and ball to the OPEN position to hold the ball in place.
8. **For 10" and 12" Valves Only:** Re-set the ball support by turning the tuning screw inwards until the support pin seat firmly contacts the ball. Do not cause the ball to move. Holding the tuning screw in place, tighten the support nut and then the set nut.
9. Install the remaining seat into body end.
10. Place new body seal into counterbore in valve body.
11. Put body end into body and align the flange bolt holes to straddle the valve centerlines.
Note: Be careful not to damage body seal when putting end into body.
12. Install body end nuts and tighten in a "Star" pattern to the torque specified in Table 2. Take care to make sure that complete engagement of studs with body flange is maintained. There should be at least one stud thread exposed on each side.
13. Tighten the gland bolts to the torques specified in Table 1.
14. Install handle, making sure that the handle aligns with the flow passage through the ball.
15. Cycle the valve open and closed several times slowly to ensure that operation is smooth and free of binding or sticking.
16. Pressure test valve, if possible, before reinstalling in pipeline.

Table 1 – Gland Bolt Torques

SIZE	Tightening Torque (lb-ft) Max
6" – 8"	42 (1/2-13UNC)
10" - 12"	83 (5/8-11UNC)

Table 2 – Body Bolting Torques

SIZE	THREAD	Tightening Torque (lb-ft) Max
6",8" (Class 150) / 3"~6"(Class 300)	5/8-11UNC	83
10",12" (Class 150) / 8"(Class 300)	3/4-10UNC	120
10"(Class 300)	7/8-9UNC	190
12"(Class 300)	1-8UNC	260